

# JELD-WEN® Steel

WOOD EDGE IMPACT GLAZED STEEL DOOR  
6-8 OUTSWING SINGLE OR DOUBLE DOOR UNIT  
UTILIZING COMPONENTS FROM ODL® INC. AND  
ENDURA PRODUCTS INC.

## GENERAL NOTES

1. THIS PRODUCT IS DESIGNED TO COMPLY WITH THE CURRENT FLORIDA BUILDING CODE (FBC) BASE ON THE SIGNED AND SEALED DATE; INCLUDING HVHZ AND HAS BEEN EVALUATED IN ACCORDANCE WITH THE FOLLOWING:

TAS 201-94 ASTM E330-02 ASTM E1886-05  
TAS 202-94 ASTM E331-00 ASTM E1996-05  
TAS 203-94 ASTM E283-91

2. WOOD BUCKS BY OTHERS, MUST BE ANCHORED PROPERLY TO TRANSFER LOADS TO THE STRUCTURE.

3. PRODUCT ANCHORS SHALL BE AS LISTED AND SPACED AS SHOWN ON DETAILS. ANCHOR EMBEDMENT TO BASE MATERIAL SHALL BE BEYOND WALL DRESSING OR STUCCO.

4. DESIGNED PRESSURE RATING SEE TABLE I, PAGE 1.

5. THIS PRODUCT MEETS THE WATER REQUIREMENTS FOR HIGH VELOCITY HURRICANE ZONE (HVHZ)

6. PRODUCT DOES NOT REQUIRE SHUTTERS

## RESIDENTIAL INSULATED STEEL DOOR (Common to all frame conditions) DOOR LEAF CONSTRUCTION:

**Face sheets:** 24 GA (0.021" min) thickness. Galvanized steel A-525 commercial quality AKDQ per ASTM 620 with average minimum yield strength  $F_y(ave)=30627$  psi.

**Core Design:** Door core by JELD-WEN.

**Panel Construction:** The active and inactive panels are constructed from 24 GA (0.021" min) galvanized steel. The face sheets at top and bottom are bent 90° over the top and bottom rails. The top rail measures 1.0" high x 1.688" wide. The steel bottom rail measures 1.21" high x 1.688" wide. The sides of the face sheets are roll formed into the latch and hinge stiles which measure 1.00" high x 1.688" wide. The interior cavity is filled with door core. The face sheets are glued to the door core. The panels are cut out for the two-piece ODL Aluminum ALLEN frame. Units are glazed with tempered and laminated impact 1" IG. On double door applications the inactive door is fitted with an extruded aluminum astragal of 6063-T5 alloy.

**Frame Construction:** The frames are constructed of fingerjointed pine jambs measuring 4-9/16" x 1-1/4". The head jambs are mortised and butt joined to the side jambs, and attached with three (3) 16GA 7/16" crown x 2" long staples on each side. The threshold is attached to the side jambs with three (3) 16GA 7/16" crown x 2" long staples on each side.

**Glazing:** ODL insulated lite is 1" overall thickness, consisting of one (1) pane of 0.125" tempered glass; 0.5" air space; two (2) panes of 0.125" annealed with .090" PVB interlayer by Solutia. All lites are sandwiched glazed into the panels.

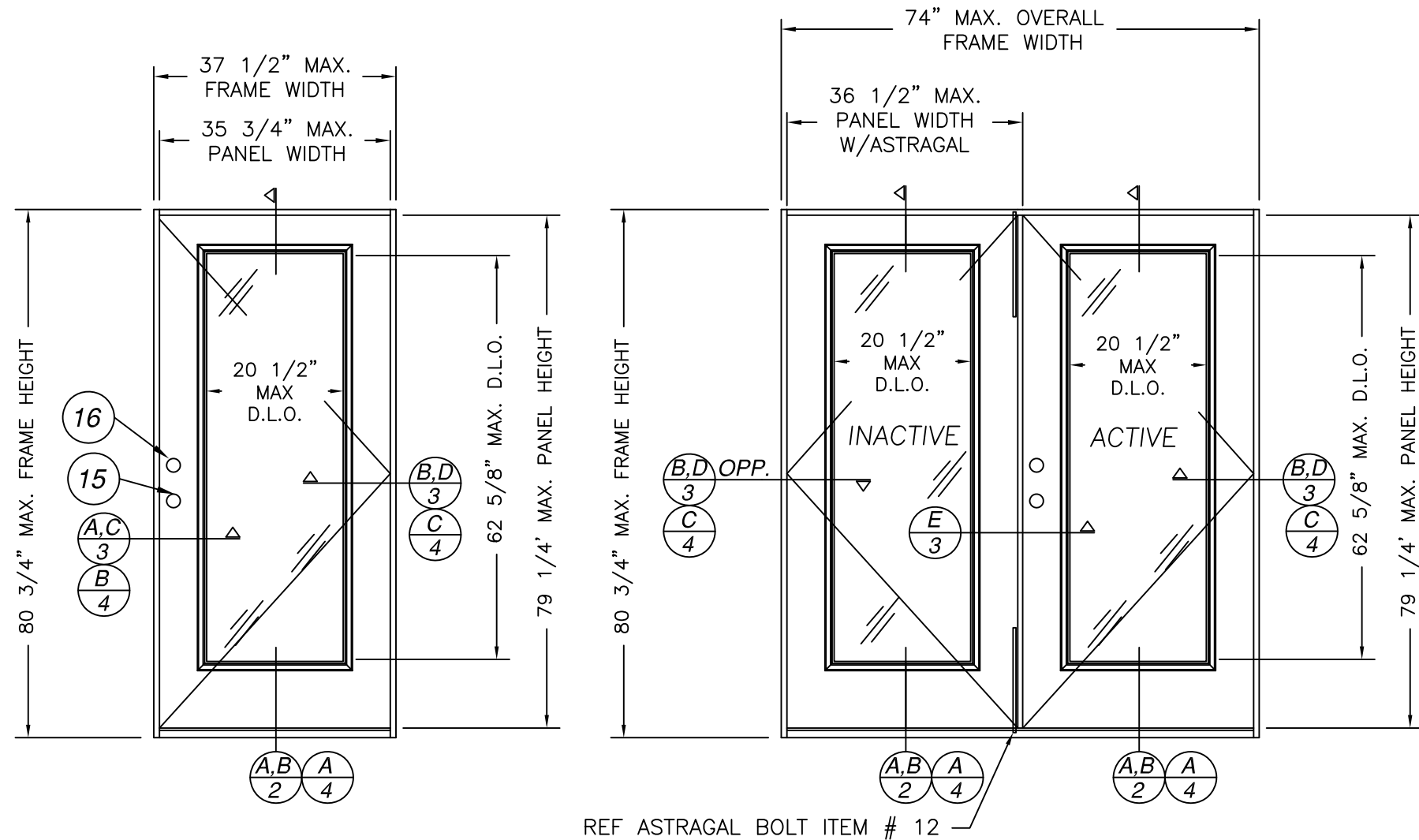

**SINGLE OUTSWING UNIT (X)**  
SCALE: 1/2" = 1'-0"

**DOUBLE OUTSWING UNIT (XX)**  
SCALE: 1/2" = 1'-0"

REF ASTRAGAL BOLT ITEM # 12

ALL DOOR MODELS ARE VIEWED  
FROM THE EXTERIOR SIDE

TABLE I		DESIGN PRESSURE RATING
/ / / / /		APPROVED FOR USE WHERE PROTECTION FOR WATER INFILTRATION IS REQUIRED
POSITIVE		+60.0 PSF
NEGATIVE		-60.0 PSF

SHEET #	DESCRIPTION
1	TYPICAL ELEVATIONS
2	VERTICAL CROSS SECTION & BILL OF MATERIAL
3	HORIZONTAL CROSS SECTIONS
4	OPTIONAL 1X BUCK IN MASONRY/CONCRETE CROSS SECTIONS
5	ANCHORING LOCATIONS
6	COMPONENT DETAILS
7	UNIT COMPONENTS

### NOTES:

- 1 - ALL VIEWS FROM EXTERIOR.
- 2 - FOR HORIZONTAL ANCHOR IN 1X BUCK OPTION IN MASONRY/CONCRETE. SEE SHEET 4 FOR DETAILS.
- 3 - FOR VERTICAL ANCHOR IN 1X BUCK OPTION IN MASONRY/CONCRETE. SEE SHEET 4 FOR DETAILS.

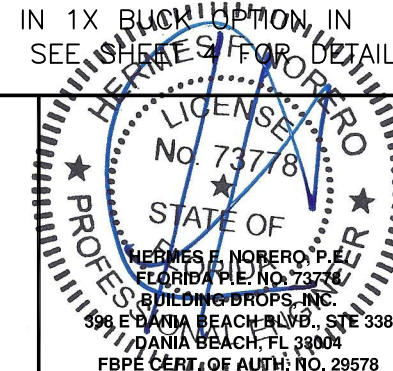

PRODUCT: WOOD EDGE IMPACT GLAZED  
STEEL DOOR 6-8 OUTSWING  
SINGLE OR DOUBLE

PART OR ASSEMBLY:  
TYPICAL ELEVATIONS &  
GENERAL NOTES

NO.	DATE	BY	REVISIONS
F 01/21/20			ADD ADA THRDLD TB
L 8/28/17			CHG CORE DEFIN. JH
D 11/17/10			GENERAL REVISION GL
C 2/5/08			ADD CONC. DWG. EAG
B 4/8/06			GENERAL REVISION/DREW
A 12/17/04			GENERAL REVISION

DATE: 6/18/13  
SCALE: AS NOTED  
DWG. BY: EAG  
CHK. BY: S. SAFFELL  
DRAWING NO.: JW0509-03  
SHEET 1 OF 7

**JELD-WEN®**  
WINDOWS & DOORS  
3737 Lakeport Blvd.  
Klamath Falls, Oregon 97601  
Ph. (541) 882-3451  
Fax (541) 850-2609

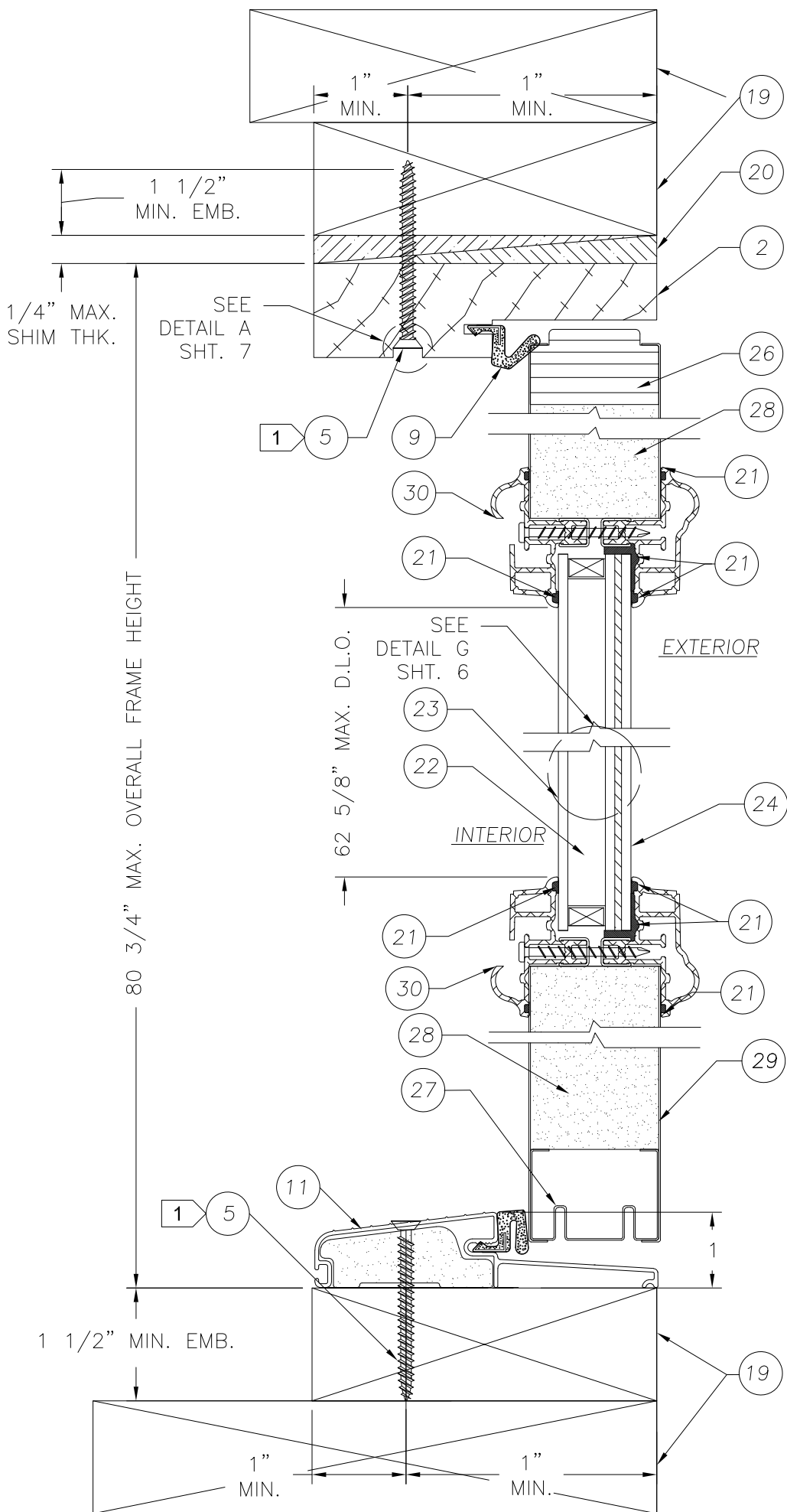

3 A VERTICAL CROSS SECTION TYP.  
2 WOOD FRAME INSTALLATION SCALE: 6" = 1'-0"

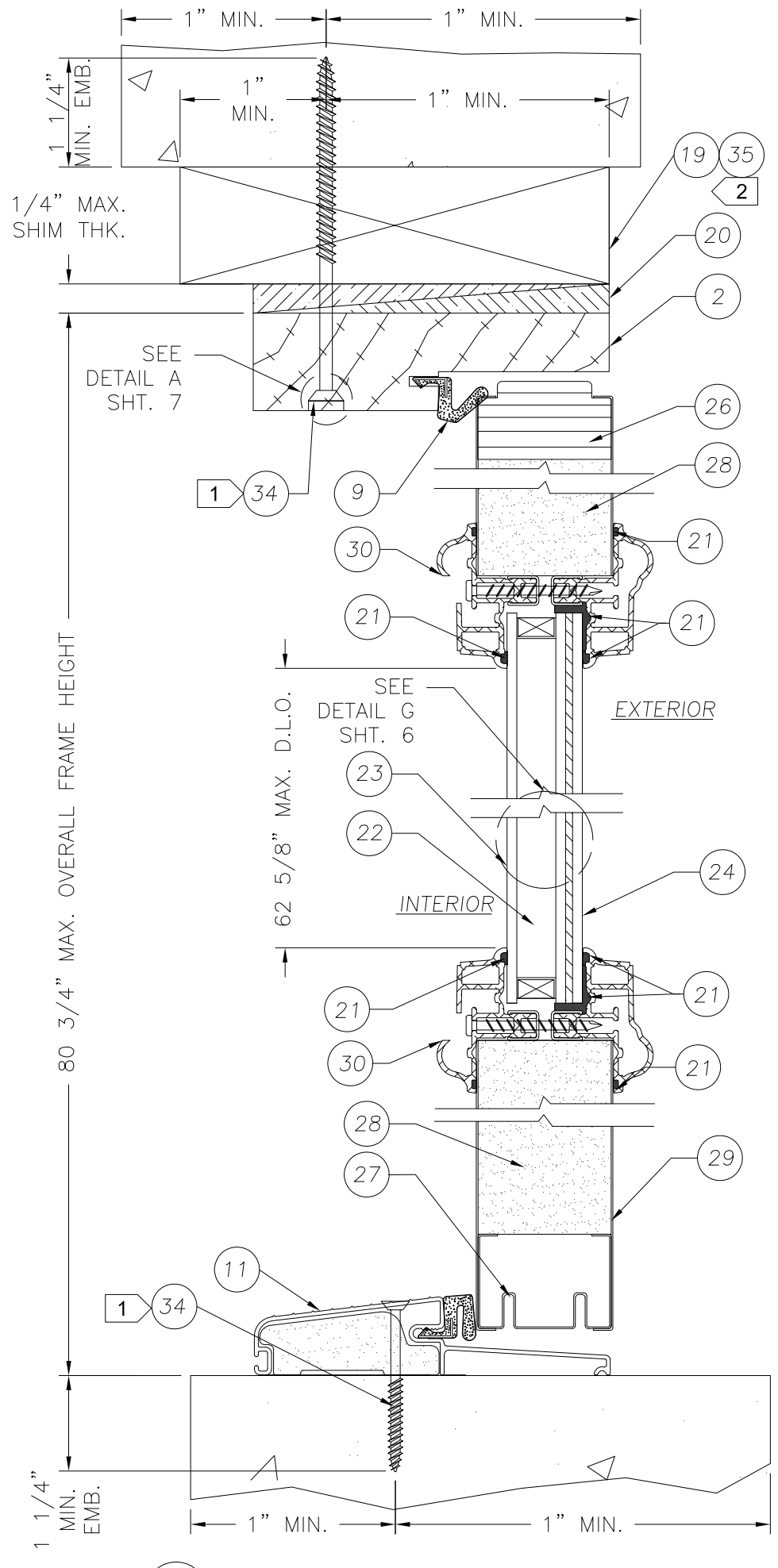

3 B VERTICAL CROSS SECTION TYP.  
2 CONCRETE INSTALLATION SCALE: 6" = 1'-0"

Item	DESCRIPTION	Material
1	SIDE JAMB (1 1/4"x 4 9/16" FINGERJOINTED PINE)	PINE
2	HEAD JAMB (1 1/4"x 4 9/16" FINGERJOINTED PINE)	PINE
3	4" x 4" BUTT HINGE 12GA. (.089" MIN)	STEEL
4	#9 x 1" PHILLIPS FLATHEAD WOOD SCREW	STEEL
5	#10 PHILLIPS HD SCREW WITH 1 1/2" MIN. EMBED.	STEEL
6	#10 X 2" PHILLIPS FLATHEAD WOOD SCREW	STEEL
7	#8 X 3" PHILLIPS FLATEHEAD WOOD SCREW	STEEL
8	#8X1" PHILLIPS FLAT HEAD WOOD SCREW	STEEL
9	COMPRESSION WEATHERSTRIP (Q-LON QDS-650)	VINYL
11	OUTSWING THRESHOLD	ALUMINUM
12	ASTRAGAL THROW BOLT, STEEL ROD, 5/16" x 18"	STEEL
13	ASTRAGAL BOLT STRIKE PLATE LOCATED ON HEAD JAMB	STEEL
14	16 Ga. 7/16" CROWN x 2" LONG STAPLES	STEEL
15	LOCK SERIES 400	STEEL
16	DEADBOLT SERIES 780	STEEL
17	HURRICANE ASTRAGAL	ALUMINUM
18	ASTRAGAL BOLT STRIKE PLATE ON BOTTOM SILL	STEEL
19	2x WOOD BUCK	WOOD
20	NON COMPRESSION SHIM	WOOD
21	DOW 995 SILICONE SEALANT	SILICONE
22	1" IMPACT IG ASSEMBLY BY ODL	GLASS
23	1/8" TEMPERED GLASS	GLASS
24	3/8" LAMINATED ANNEALED GLASS	GLASS
25	LOCK BLOCK (SOLID WOOD x 12" LG)	WOOD
26	TOP RAIL (LVL)	LVL
27	BOTTOM RAIL (25GA MIN GALVANIZED STEEL)	STEEL
28	DOOR CORE BY JELD-WEN	FOAM
29	STEEL DOOR PANEL SKIN MATERIAL (24GA GALVANIZED) A-525 COMMERCIAL QUALITY 0.021" MIN. THICK.)	GALVANIZED
30	ODL LITE ALLEN FRAME (ALUM 6063 T5)	ALUMINUM
31	HINGE SIDE STILE (FINGER JOINTED LVL)	LVL
32	LATCH SIDE STILE (FINGER JOINTED LVL)	LVL
33	#8 x 2" PHILLIPS FLATHEAD WOOD SCREW	STEEL
34	3/16" ITW BUILDDEX TAPCON WITH 1.25" MIN. EMBEDMENT	STEEL
35	OPTIONAL 1x WOOD BUCK	WOOD
36	FLAT LITE KIT	ALUMINUM
37	ADA THRESHOLD	ALUMINUM
38	ODL FOAM IN PLACE GASKET	FOAM

- NOTES:
- 1 FOR TAPCON MASONRY AND WOOD SCREW ANCHOR SPACING (ITEMS #5 & #34), SEE SHEET 5.
  - 2 FOR VERTICAL ANCHOR IN 1X BUCK OPTION IN MASONRY/CONCRETE. SEE SHEET 4 FOR DETAILS.
  - 3 OPTIONALLY, ANCHOR CAN BE PLACED IN NARROW SECTION OF HEAD OR JAMB AS LONG AS MINIMUM EMBEDMENT IS ACHIEVED.

**JELDOWEN**  
WINDOWS & DOORS  
3737 Lakeport Blvd.  
Klamath Falls, Oregon 97601  
Ph. (541) 882-3451  
Fax (541) 850-2609

PRODUCT: WOOD EDGE IMPACT GLAZED  
STEEL DOOR 6-8 OUTSWING  
SINGLE OR DOUBLE

PART OR ASSEMBLY:  
VERTICAL CROSS SECTIONS  
BILL OF MATERIAL

NO.	DATE	REVISIONS
F	01/21/20	ADD ADA THRESHOLD TB
E	8/28/17	CHG CORE DEFIN: JH
D	11/17/10	GENERAL REVISION GL
C	2/5/08	ADD CONC. DWG. EAG
B	4/8/06	GENERAL REVISIONDREW
A	12/17/04	GENERAL REVISION

DATE: 6/18/13  
SCALE: AS NOTED  
DWG. BY: EAG  
CHK. BY: S. SAFFELL  
DRAWING NO.: JW0509-03  
SHEET 2 OF 7



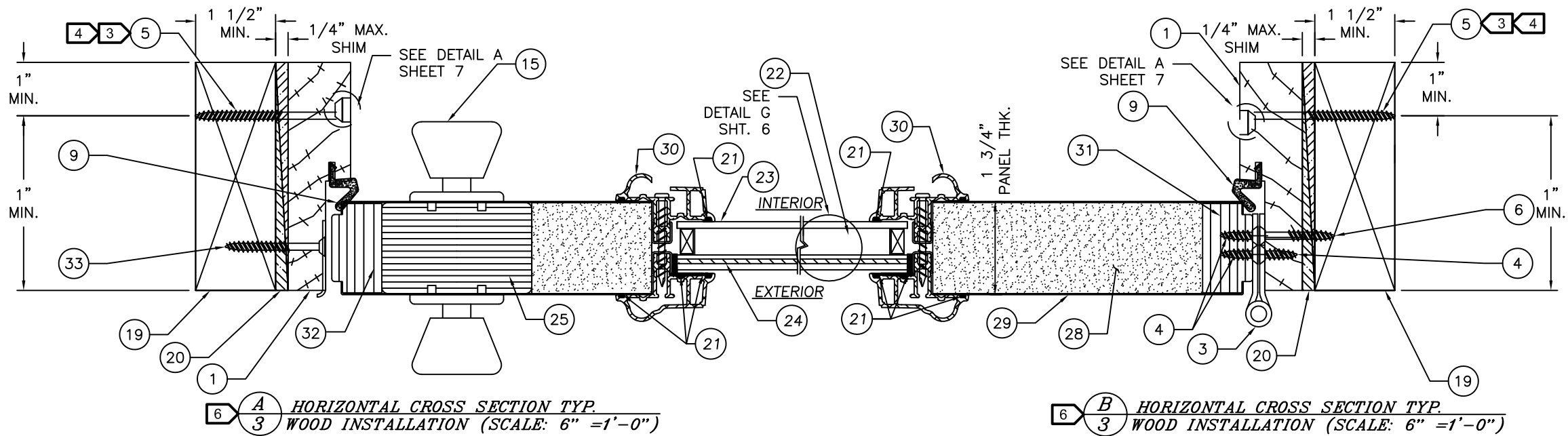

**A** HORIZONTAL CROSS SECTION TYP.  
**3** WOOD INSTALLATION (SCALE: 6" = 1'-0")

**B** HORIZONTAL CROSS SECTION TYP.  
**3** WOOD INSTALLATION (SCALE: 6" = 1'-0")

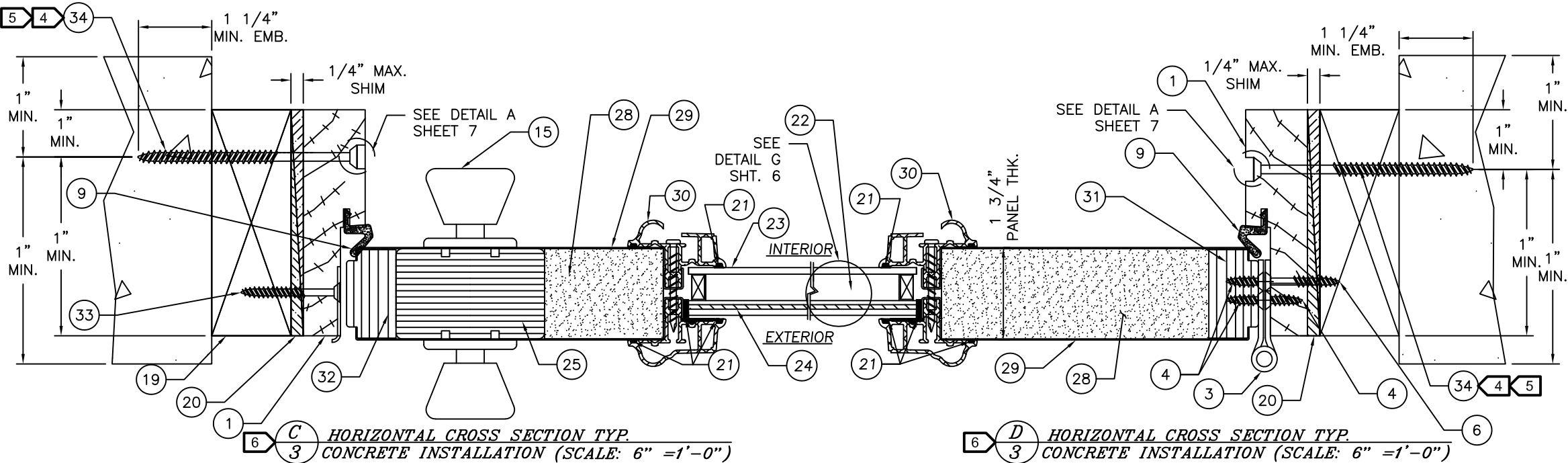

**C** HORIZONTAL CROSS SECTION TYP.  
**3** CONCRETE INSTALLATION (SCALE: 6" = 1'-0")

**D** HORIZONTAL CROSS SECTION TYP.  
**3** CONCRETE INSTALLATION (SCALE: 6" = 1'-0")

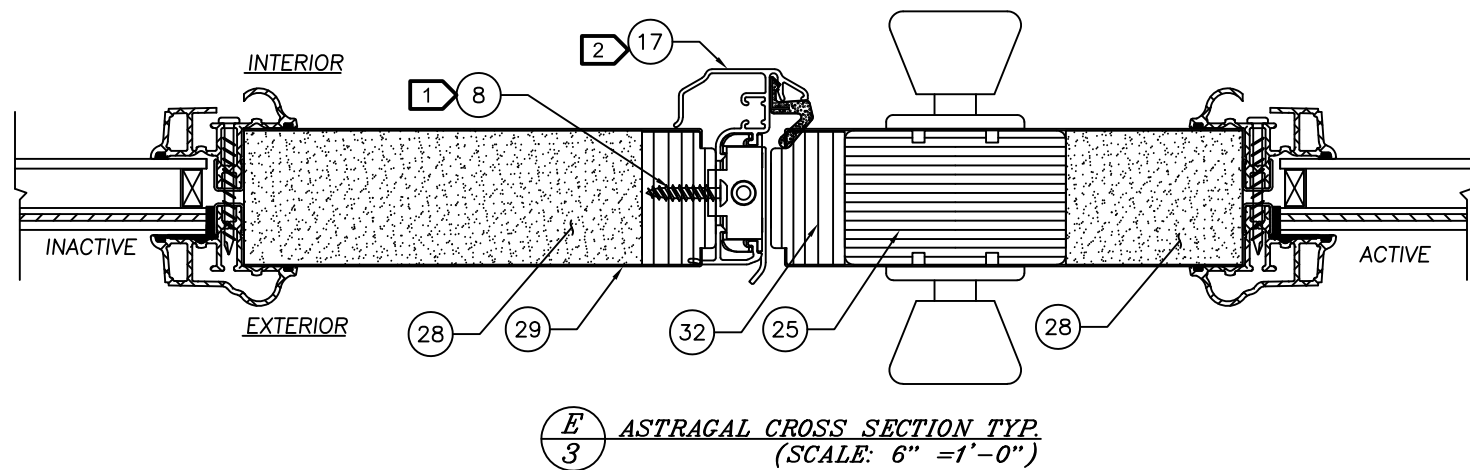

**E** ASTRAGAL CROSS SECTION TYP.  
**3** (SCALE: 6" = 1'-0")

- NOTES:
- 1** ASTAGAL FASTENER SPACING DETAIL F, SHEET 6. (TOTAL OF 14 SCREWS).
  - 2** LATCH AND DEADBOLT STRIKE PLATES MOUNT TO ASTAGAL WITH ADJUSTABLE NUT PLATES. BOTH PLATES REQUIRE #8 X 3" PHILLIPS FLAT HEAD WOOD SCREWS.
  - 3** 2x BUCK TO SUBSTRATE FASTENING MAY UTILIZE OPTIONAL 3/16" ITW BUILDEX TAPCON.
  - 4** FOR TAPCON MASONRY AND WOOD SCREW ANCHOR SPACING (ITEMS #5 & #34), SEE SHEET 5.
  - 5** FOR HORIZONTAL ANCHOR IN 1X BUCK OPTION IN MASONRY/CONCRETE. SEE SHEET 4 FOR DETAILS.
  - 6** OPTIONALLY, ANCHOR CAN BE PLACED IN NARROW SECTION OF HEAD OF JAMB AS LONG AS MINIMUM EMBEDMENT IS ACHIEVED.

**JELDOWEN**  
 WINDOWS & DOORS  
 3737 Lakeport Blvd.  
 Klamath Falls, Oregon 97601  
 Ph. (541) 882-3451  
 Fax (541) 850-2609

PRODUCT: WOOD EDGE IMPACT GLAZED  
 STEEL DOOR 6-8 OUTSWING  
 SINGLE OR DOUBLE

PART OR ASSEMBLY:  
 HORIZONTAL CROSS SECTIONS

NO.	DATE	REVISIONS	BY
F 01/21/20		ADD ADA THRESHOLD	TB
E 8/28/17		CHG CORE DEFIN.	JH
D 11/17/10		GENERAL REVISION	GL
C 2/5/08		ADD CONC. DWG.	EAG
B 4/8/06		GENERAL REVISION	DREW
A 12/17/04		GENERAL REVISION	DREW

DATE: 6/18/13  
 SCALE: AS NOTED  
 DWG. BY: EAG  
 CHK. BY: S. SAFFELL  
 DRAWING NO.: JW0509-03  
 SHEET 3 OF 7

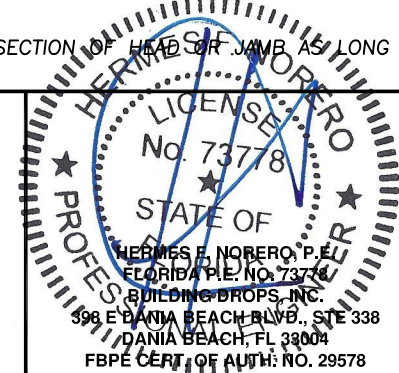

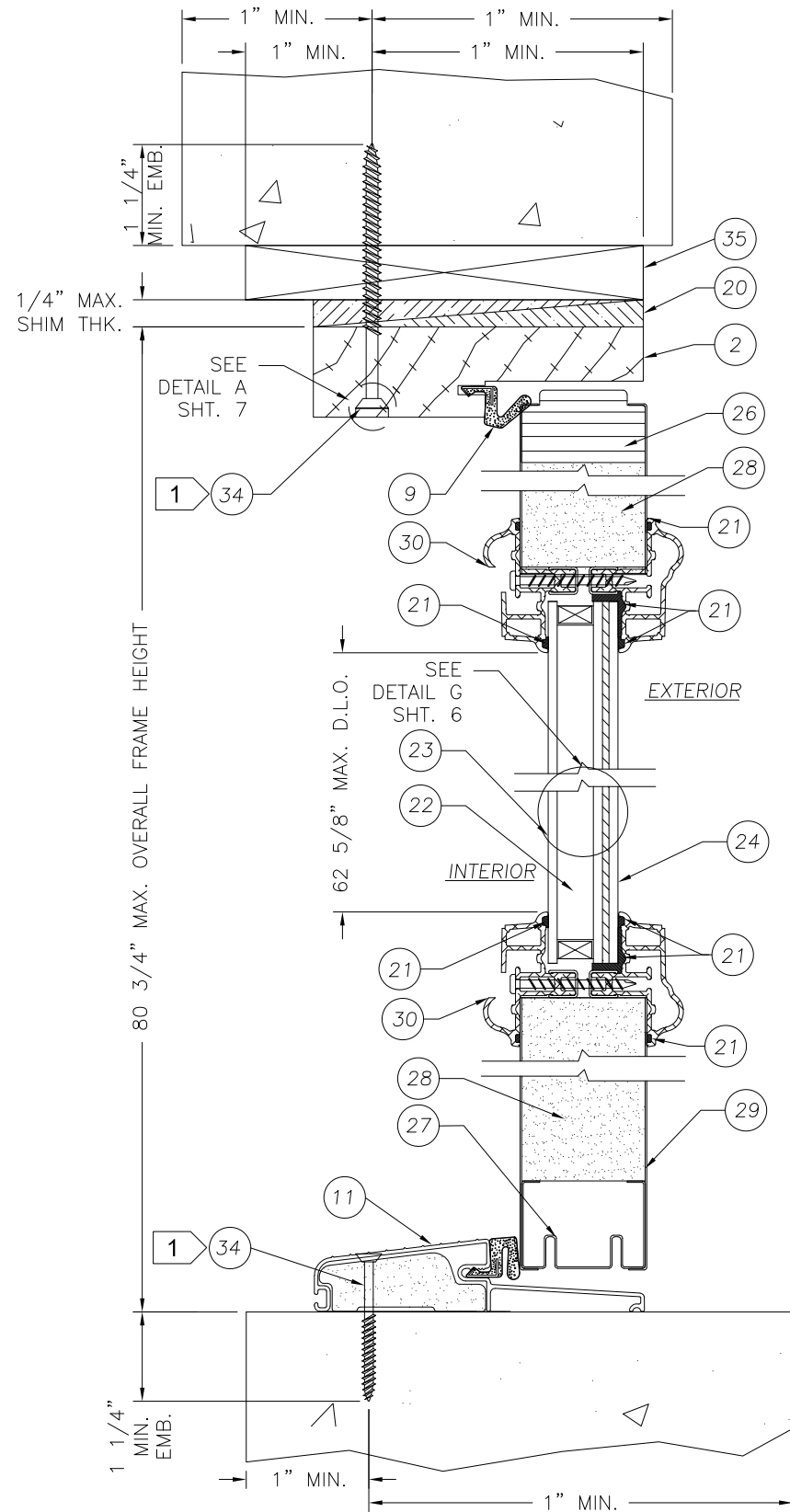

2 **A** **4** VERTICAL CROSS SECTION TYP.  
OPERATING UNIT 1X BUCK  
OPTION IN MASONRY/CONCRETE  
(SCALE: 6" = 1'-0")

2 **B** **4** HORIZONTAL CROSS SECTION TYP.  
OPERATING UNIT 1X BUCK  
OPTION IN MASONRY/CONCRETE  
(SCALE: 6" = 1'-0")

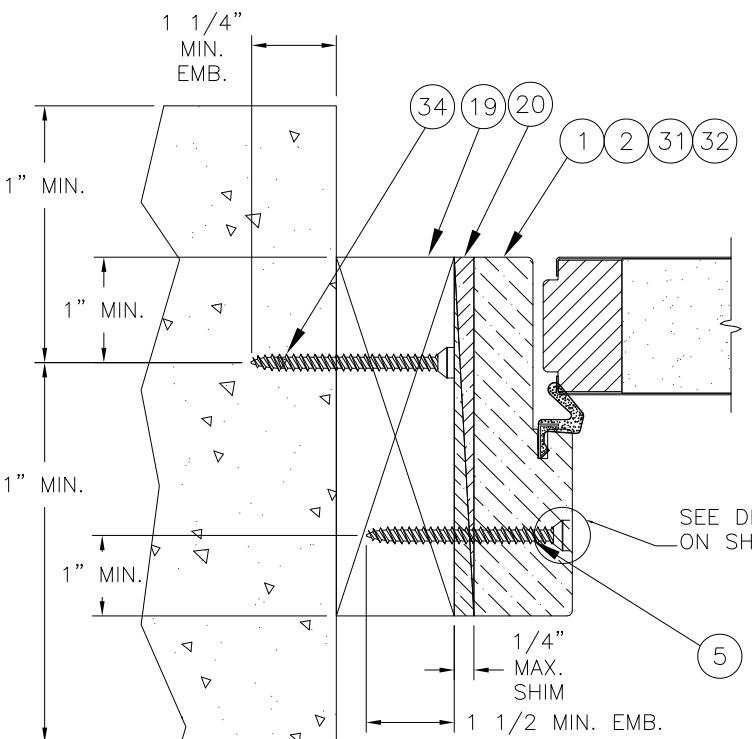
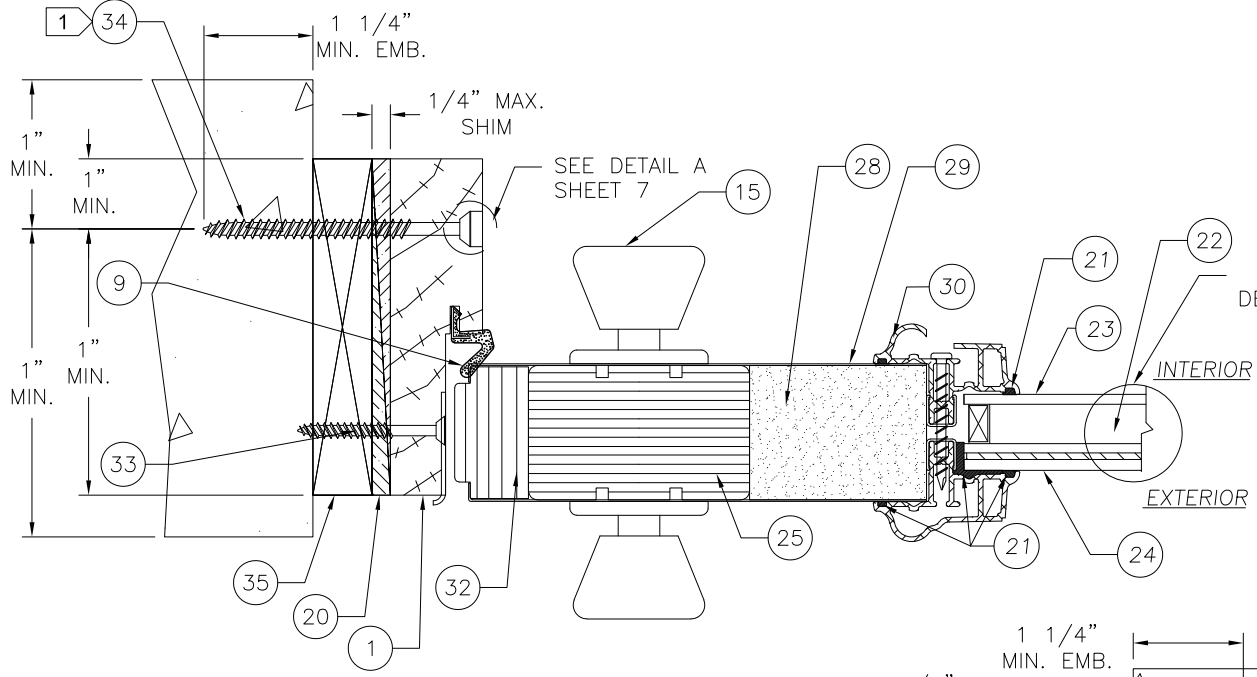

2 **B** **4** CROSS SECTION OF HEAD OR JAMB  
OPERATING UNIT 2X BUCK  
OPTION IN MASONRY/CONCRETE  
(SCALE: 6" = 1'-0")

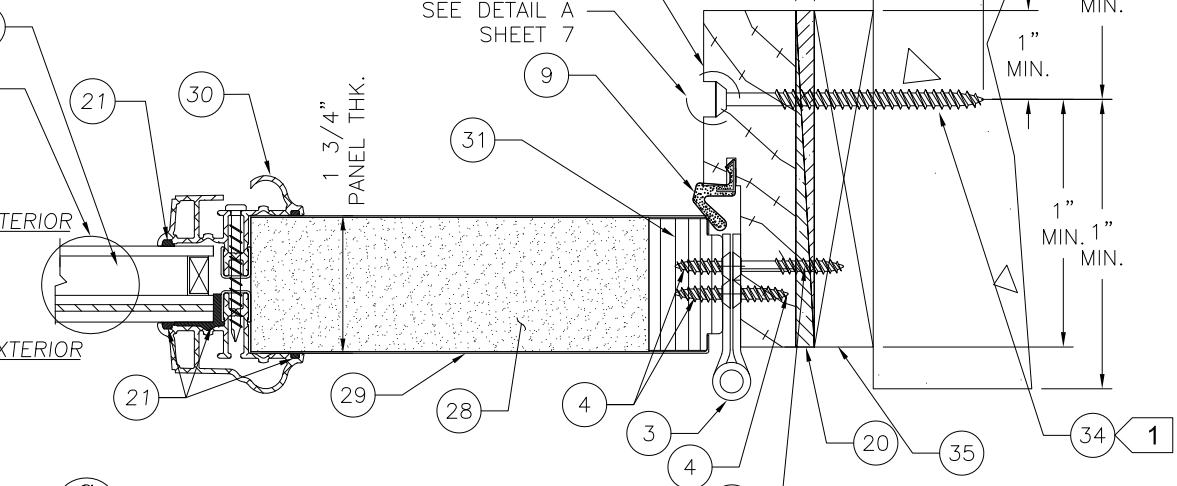

2 **C** **4** HORIZONTAL CROSS SECTION TYP.  
OPERATING UNIT 1X BUCK  
OPTION IN MASONRY/CONCRETE  
RIGHT HINGE SHOWN, LEFT HINGE OPPOSITE SHOWN  
(SCALE: 6" = 1'-0")

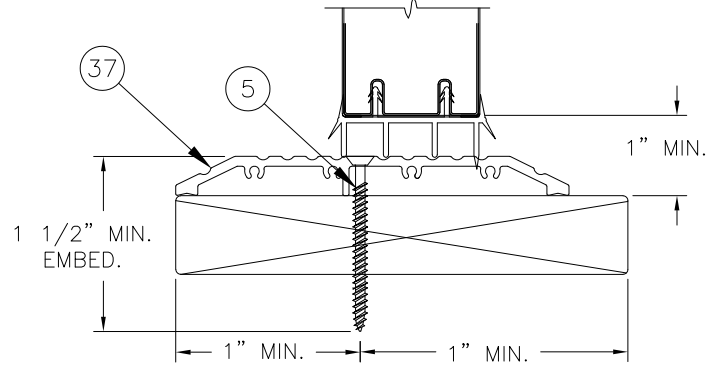

2 **A** **4** VERTICAL CROSS SECTION (SILL)  
OPERATING UNIT 1X BUCK  
OPTIONAL ADA SILL  
(SCALE: 6" = 1'-0")

- NOTES:
- 1 FOR TAPCON MASONRY AND WOOD SCREW ANCHOR SPACING (ITEMS #5 & #34), SEE SHEET 5.
  - 2 OPTIONALLY, ANCHOR CAN BE PLACED IN NARROW SECTION HEAD OR JAMB AS LONG AS MINIMUM EMBEDMENT IS ACHIEVED.

**JELDOWEN**  
WINDOWS & DOORS  
3737 Lakeport Blvd.  
Klamath Falls, Oregon 97601  
Ph. (541) 882-3451  
Fax (541) 850-2609

PRODUCT: WOOD EDGE IMPACT GLAZED  
STEEL DOOR 6-8 OUTSWING  
SINGLE OR DOUBLE  
PART OR ASSEMBLY:  
1X BUCK & OPTIONAL INSTALL IN  
CONCRETE/MASONRY CROSS SECTIONS

NO.	DATE	REVISIONS	BY
F 01/21/20		ADD ADA THRESHOLD	TB
E 8/28/17		CHG CORE DEFIN.	JH
D 11/17/10		GENERAL REVISION	GL
C 2/5/08		ADD CONC. DWG.	EAG
B 4/8/06		GENERAL REVISION	DREW
A 12/17/04		GENERAL REVISION	BY

DATE: 6/18/13  
SCALE: AS NOTED  
DWG. BY: EAG  
CHK. BY: S. SAFFELL  
DRAWING NO.: JW0509-03  
SHEET 4 OF 7

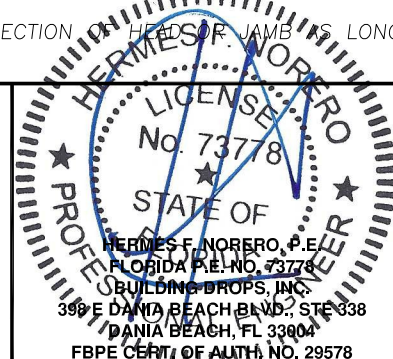

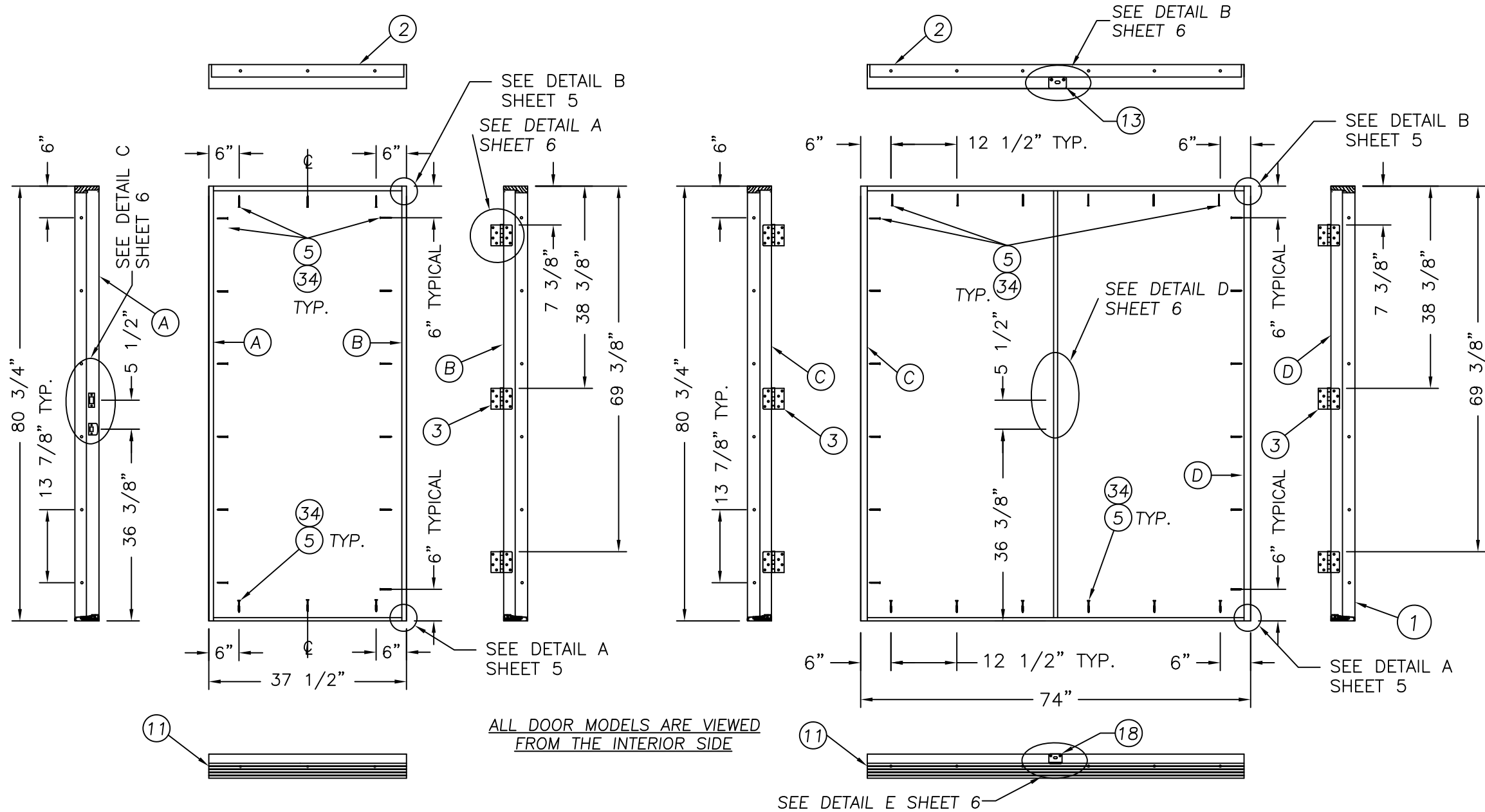

**ANCHORING LOCATIONS  
OUTSWING SINGLE UNIT (X)**  
SCALE: 1/2" = 1'-0"

**ANCHORING LOCATIONS DOUBLE  
OUTSWING UNIT (XX)**  
SCALE: 1/2" = 1'-0"

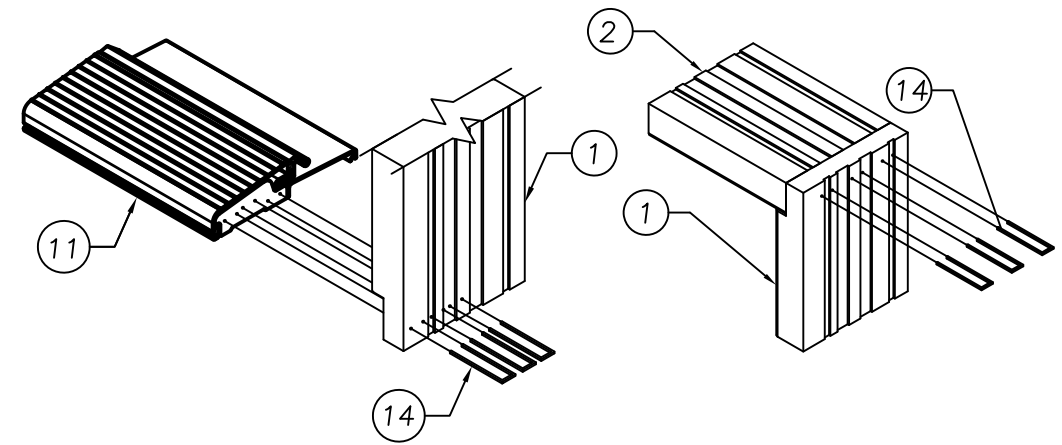

**DETAIL A**  
SCALE: 3" = 1'-0"

**DETAIL B**  
SCALE: 3" = 1'-0"

**JELDOWEN**  
WINDOWS & DOORS  
3737 Lakeport Blvd.  
Klamath Falls, Oregon 97601  
Ph. (541) 882-3451  
Fax (541) 850-2609

PRODUCT: WOOD EDGE IMPACT GLAZED  
STEEL DOOR 6-8 OUTSWING  
SINGLE OR DOUBLE

PART OR ASSEMBLY:  
ANCHORING LOCATIONS  
& DETAILS

NO.	DATE	BY	REVISIONS
F 01/21/20			ADD ADA THIRHOLD TB
E 8/28/17			CHG CORE DEFIN. JH
D 11/17/10			GENERAL REVISION GL
C 2/5/08			ADD CONC. DWG. EAG
B 4/8/06			GENERAL REVISION DREW
A 12/17/04			GENERAL REVISION

DATE: 6/18/13  
SCALE: AS NOTED  
DWG. BY: EAG  
CHK. BY: S. SAFFELL  
DRAWING NO.: JW0509-03  
SHEET 5 OF 7

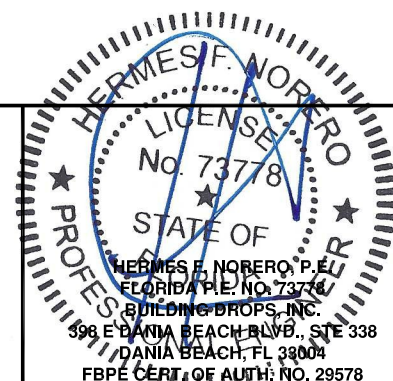



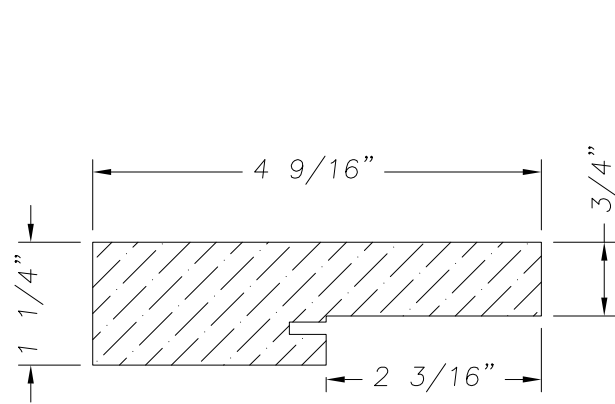

1 WOOD JAMB FINGERJOINTED PINE  
SCALE: 6" = 1'-0"

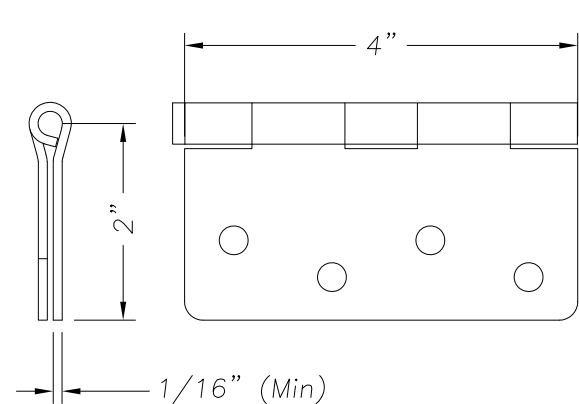

3 BUTT HINGE 4x4x12 GA.  
SCALE: 6" = 1'-0"

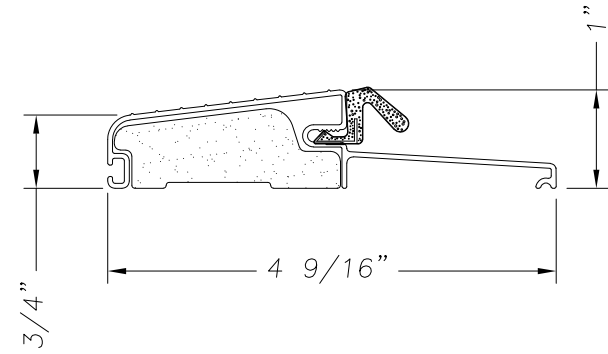

11 OUTSWING THRESHOLD  
SCALE: 6" = 1'-0"

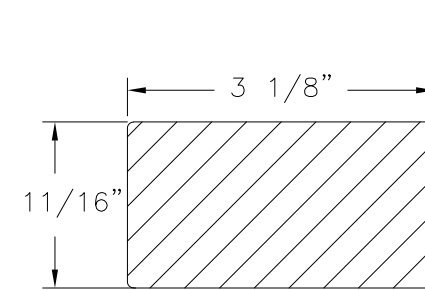

25 LOCK BLOCK - WOOD  
SCALE: 6" = 1'-0"

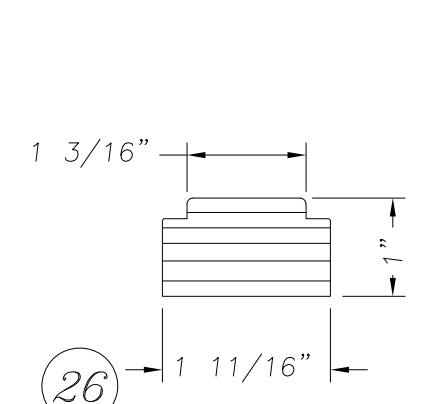

26  
31 TOP RAIL (LVL)  
HINGE STILE (LVL)  
LATCH STILE (LVL)  
SCALE: 6" = 1'-0"

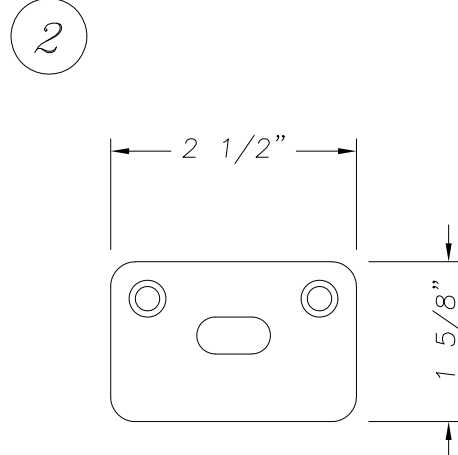

13 ASTRAGAL STRIKE PLATE  
SCALE: 6" = 1'-0"

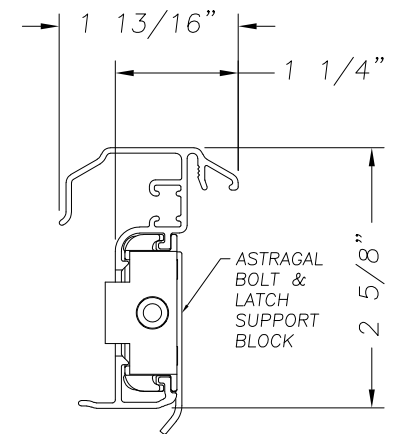

17 ALUMINUM ASTRAGAL  
SCALE: 6" = 1'-0"

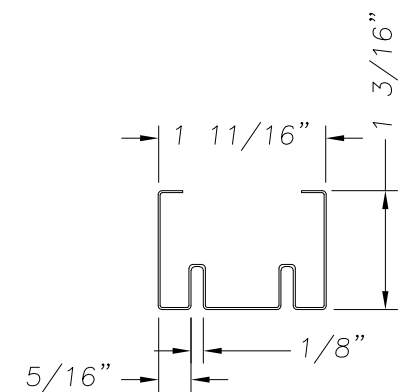

27 BOTTOM RAIL  
STEEL, 25GA MIN. GALV.  
SCALE: 6" = 1'-0"

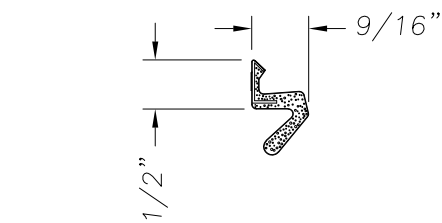

9 COMPRESSION WEATHERSTRIP  
QDS-650 SCALE: 6" = 1'-0"

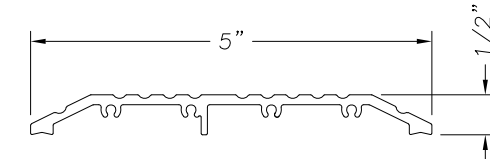

37 OPERABLE ADA SILL  
ALUMINUM

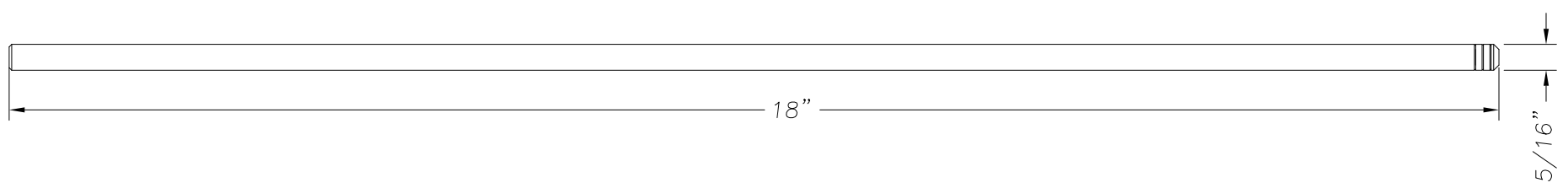

12 ASTRAGAL BOLT  
MAT. - C/R STEEL ROD  
ZINC & YELLOW CHROMATE  
SCALE: 6" = 1'-0"

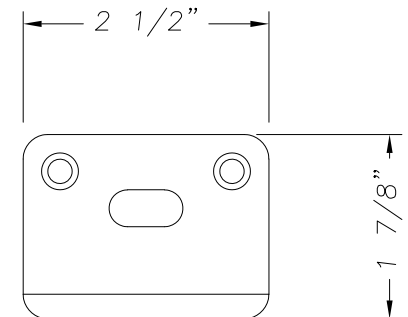

18 ASTRAGAL SILL  
STRIKE PLATE  
SCALE: 6" = 1'-0"

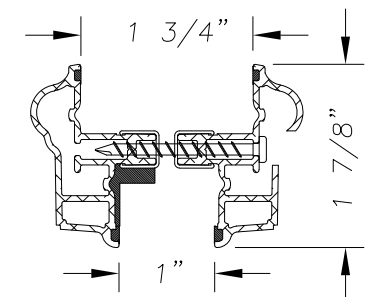

30 ODL ALLEN FRAME  
ALUMINUM 6063 T5  
SCALE: 6" = 1'-0"

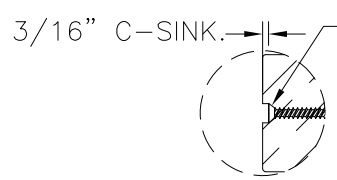

NOTE  
1-USE #10 WOOD INSTALLATION SCREW W/ 1 1/2" MIN. EMBEDMENT  
WHEN INSTALLING INTO WOOD SUBSTRATE AT HEAD & JAMBS.  
2-USE #8 x 2 1/2" PFH WOOD SCREW WHEN INSTALLING INTO MULLIONS.  
3-USE 3/16" ITW TAPCON ANCHOR W/ 1 1/4" MIN. EMBED.  
WHEN INSTALLING INTO CONCRETE/MASONRY SUBSTRATE AT SIDELITE SILLS.

DETAIL A - COUNTERSINK DETAIL  
SCALE: 1/4" = 1'-0"

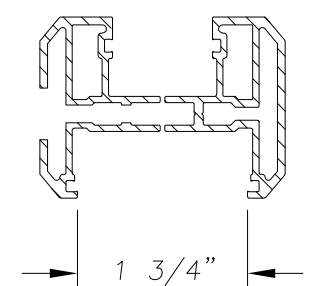

36 FLAT LITE KIT

**JELLOWEN**  
WINDOWS & DOORS  
3737 Lakeport Blvd.  
Klamath Falls, Oregon 97601  
Ph. (541) 882-3451  
Fax (541) 850-2609

PRODUCT: WOOD EDGE IMPACT GLAZED  
STEEL DOOR 6-8 OUTSWING  
SINGLE OR DOUBLE  
PART OR ASSEMBLY:  
UNIT COMPONENTS

NO.	DATE	REVISIONS	BY
F 01/21/20		ADD ADA THRESHOLD	TB
E 8/28/17		CHG CORE DEFIN.	JH
D 11/17/10		GENERAL REVISION	GL
C 2/5/08		ADD CONC. DWG.	EAG
B 4/8/06		GENERAL REVISION	DREW
A 12/17/04		GENERAL REVISION	

DATE: 6/18/13  
SCALE: AS NOTED  
DWG. BY: EAG  
CHK. BY: S. SAFFELL  
DRAWING NO.: JW0509-03  
SHEET 7 OF 7

